

**व्यापक परिचालन में मसौदा**

प्रलम्ब प्रेषण सजापन	
सदस्य	दिनांक
एम.ई.डी 16:3/टी-48 & 49	17-01-2012

तकनीकी समिति: एम.ई.16:

- 1 यॉन्गिक इंजिनियरी विभाग परिषद का सभी सदस्य(यॉ.वि.प.) ।
- 2 गैस सिलिंडर विषय समिति एम.ई.डी. 16 एष घुलित ऐसिटिलीन सिलिंडर, जनरलर, ऐसिटिलीन पाईपलाइन एष उच्च दाव गैस सिलिंडर उप समिति एम.ई.डी 16:3 का सभी सदस्य ।
- 3 अन्य रूचि रखनवाला।

निम्नलिखित प्रलम्ब सलग्न है:

प्रलम्ब	विषय
एम.ई. 16 (1126)	भारतीय मानक मसौदा घुलनशील एसीटलीन गैस सिलिंडरों का निरीक्षण और रख-रखाव की रीति संहिता (पहला पुनरीक्षण) (आईसीएस 23.020.30)
एम.ई. 16 (1127)	भारतीय मानक मसौदा घुलनशील एसीटलीन गैस सिलिंडरों का भरनका समय निरीक्षण की रीति संहिता (पहला पुनरीक्षण) (आईसीएस 23.020.30)

कृपया इस मसौदाका अवलोकन करें और अपनी सम्मतियायह बतातहुए भजें कि अस्ततः यदि यह प्रकाशित ह जाएँ त इस पर अमल करन में आपका व्यवसाय अथवा कारखार में क्या कठिनाईयाँ आ सकती हैं ।

सम्मतियाभजनकी अन्तिम तिथि: **16-02-2012**.

यदि कोई सम्मति ह त कृपया अगलपृष्ठ पर दियापत्र में अद्यहस्ताक्षरी का उपरिलिखित ई-मल पर भज दें ।

यदि कोई सम्मति प्राप्त नहीहसी हैं अथवा सम्मति में कवल भाषा सबधी त्रुटि हुई त उपरलम्ब प्रलम्ब का यथावत अन्तिम रूप दिया जायगा । यदि कोई सम्मति तकनीकी प्रकृति की हुई त विषय समिति का अध्यक्ष का परामर्श सअथवा उनकी इच्छा पर आगकी कार्यवाही का लिए विषय समिति का भजनजानका बाद प्रलम्ब का अन्तिम रूप ददिया जाएगा ।

यह मसौदाहमारी वब साईट [www.bis.org.in](http://www.bis.org.in) पर भी उपलब्ध हैं ।

धन्यवाद,

भवदीय

हस्ताक्षर :

नाम : जए सिददकी

पद . वैज्ञा. 'ई' एवप्रमुख (यॉइजि.)

फाम/फैक्स: 011-23232509

ई-मल: [med@bis.org.in](mailto:med@bis.org.in)

प्रति: उपरिलिखित

नाट - जहाएक सठाठन का मुख्य और वैकल्पिक सदस्य एक ही स्टथान पर हैं, मसौदाकी एक प्रतिलिपि कवल मुख्य सदस्य का भजी जा रही है। व मसौदाका वैकल्पिक सदस्य का साथ साझा करनका कष्ट करें ।

**DRAFT STANDARD IN**  
**WIDE CIRCULATION**

**DOCUMENT DESPATCH ADVICE**  
Ref: ME 16 :3/T-48 & 49      Date: 17-01-2012

Gas Cylinders, Sectional Committee, ME 16

TO:

- a) The interested members of Mechanical Engineering Division Council, MEDC
- b) All members of Gas Cylinders Sectional Committee, ME 16 and Dissolved Acetylene Cylinders, Generators, Acetylene Pipelines and High Pressure Gas Cylinders Sub Committee, ME 16:3
- c) All others Interested

Dear Sirs,

Please find enclosed the following documents:

Doc. No.	TITLE
Doc: MED 16 (1126)	Draft Indian Standard Code of practice for periodic inspection and maintenance of dissolved acetylene gas cylinders (First Revision) (ICS 23.020.30)
Doc: MED 16 (1127)	Draft Indian Standard Code of practice for inspection at time of filling for dissolved acetylene gas cylinders (First Revision) (ICS 23.020.30)

Kindly examine the Draft Standards and forward your views stating any difficulties which you are likely to experience in your business or profession, if this is finally adopted.

Last date for receipt of comments: **16-02-2012**.

Comments, if any, may please be made in the format as given overleaf and e-mailed to the undersigned at the above address.

In case no comments are received or comments received are of editorial nature, you will kindly permit us to presume your approval for the above document as finalized. However, in case of comments of technical in nature are received then it may be finalized either in consultation with the Chairman, Sectional Committee or referred to the Sectional committee for further necessary action if so desired by the Chairman, Sectional Committee.

The document is also hosted on BIS website [www.bis.org.in](http://www.bis.org.in).

Thanking you,

Yours faithfully

(J.A. Siddiqui)  
Scientist 'E' & Head (Mech Engg)  
Phone/Fax: 011-23232509  
E-mail: [med@bis.org.in](mailto:med@bis.org.in)

Encl: As above

**NOTE-WHERE PRINCIPAL AND ALTERNATE MEMBERS OF AN ORGANISATION ARE FROM THE SAME STATION, ONE COPY OF THE DOCUMENT IS SENT ONLY TO THE PRINCIPAL MEMBER WHO MAY KINDLY SHARE THIS WITH HIS ALTERNATE AS WELL.**



**DRAFT FOR COMMENTS ONLY**

**Draft Indian Standard**  
**CODE OF PRACTICE FOR INSPECTION AT TIME OF FILLING FOR**  
**DISSOLVED ACETYLENE GAS CYLINDERS**

**ICS 23.020.30**

---

**Not to be reproduced without the permission of BIS  
or used as a STANDARD**

**Last date for receipt of  
comments is: 20 February 2012**

---

**FOREWORD**

Adoption clause to be added later on.

**0.1** The Gas Cylinder Rules 2004 and the Indian Standard Specifications relating to compressed gas cylinders require that a cylinder be subjected to the pre-fill and post-fill inspections by the competent person of licensed cylinder filling station. Standard covers requirements that reflect current practice and experience considering the provisions of the Gas Cylinder Rules 2004.

**0.2** Each gas cylinder for dissolved acetylene is inspected at time of filling in order to establish that:

- i) It has no defects such that the cylinder is unsafe for filling or continued use;
- ii) It can be identified and complies with the relevant requirements with regard to marking, labelling, colour coding and completeness of its accessories;
- iii) Its valve functions satisfactorily;
- iv) The appropriate amounts of solvent and acetylene have been determined and charged.

**0.3** The cylinder filling inspection is to be carried out only by persons who are trained and competent in the subject, for the purpose of ensuring that a cylinder is safe for continued use.

In the preparation of this standard considerable assistance has been taken from ISO 11372:2011 “Gas Cylinders – Cylinders for Dissolved acetylene – inspection at time of filling”.

**0.4** While implementing this standard compliance with statutory regulations shall be ensured.

**0.5** For the purpose of deciding whether a particular requirement of this standard is complied with, the final value, observed or calculated, expressing the result of a test or analysis, shall be rounded off in accordance with IS 2:1960 ‘Rules for rounding off numerical values (*revised*)’. The number of significant places retained in the rounded off value should be the same as that of the specified value in this standard.

**1 SCOPE**

This standard specifies minimum requirements for inspection at time of filling of single cylinders for the safe storage and transport of dissolved acetylene gas under pressure;

- i) Is not applicable to palletized cylinders, or to manifold cylinders or manifold bundles on trailers;
- ii) Does not cover aspects related to the inspection or testing of the porous material.

## **2 TERMINOLOGY**

For the purpose of this standard, the following definitions in addition to given in IS 7241 shall apply.

**2.1 Acetylene Bundle** - Transportable unit consisting of two or more acetylene cylinders manifolded together within a rigid frame, equipped with all necessary equipment for filling and emptying in the assembled state.

**2.2 Dissolved Acetylene Cylinder** - Dissolved acetylene cylinder means a cylinder having a valve and with or without safety devices, containing a porous mass, a solvent for the storage of dissolved acetylene and at least sufficient acetylene to saturate the solvent at atmospheric pressure and at a temperature of +15 °C.

**NOTE** - Acetone or any other solvent used shall not be capable of chemical reaction with the acetylene gas or with the porous mass or with the metal of the cylinder or valve;

**2.3 Acetylene/Solvent Ratio** - Ratio of the maximum acetylene content to the specified solvent content.

**2.4 Competent Authority** - Any national body or authority designated or otherwise recognized as such for any purpose in connection with this standard.

**2.5 Competent Person** - Person who by a combination of training, experience and supervision is able to make objective judgments on a subject, authorized by the Competent Authority.

**2.6 Complete Cylinder** - Cylinder shell ready to be charged with acetylene gas that is complete with porous mass, solvent (where applicable), saturation gas (where applicable), valve and any valve protection permanently fixed to the cylinder shell.

**2.7 Cylinder Shell** - Pressure vessel manufactured and suitable for receiving and containing a porous mass and to be filled as an acetylene cylinder.

**2.8 Manufacturer** - Company responsible for filling the cylinder shell with porous mass and which generally prepares it for the first charge of acetylene.

**2.9 Maximum Acetylene Content** - Specified maximum mass of acetylene the cylinder is designed to contain.

NOTES:

- 1** Maximum acetylene content is expressed in kilograms.
- 2** When a solvent is used, it includes the saturation gas.

**2.10 Maximum Permissible Settled Pressure** - Maximum permissible gauge pressure, at a uniform temperature of 15°C, in a cylinder containing the maximum acetylene content and the specified solvent content.

**NOTE** - Maximum permissible settled pressure is expressed in bar.

**2.11 Porosity** - Ratio of the total volume (water capacity) of the cylinder shell minus the volume of the solid material of the porous mass, to the water capacity of the cylinder shell.

**NOTE** - Porosity is expressed as a percentage.

**2.12 Porous Mass Porous Substance** - Single or multi-component material introduced or formed in the cylinder shell in order to fill it and that, due to its porosity, allows the absorption of the solvent and acetylene gas solution.

NOTE - The porous mass may be monolithic or non-monolithic. Monolithic porous mass consists of a solid product typically obtained by reacting materials or by bonding materials together with a binder. Non-monolithic porous mass consists typically of granular, fibrous or similar materials without addition of a binder.

**2.13 Solvent** - Liquid that is absorbed by the porous mass and is capable of dissolving and releasing the acetylene.

### **2.14 Tare Weight**

- 1) Acetylene cylinder means the weight of the cylinder together with any fittings, permanently attached and includes the weight of valve any safety device, porous mass, requisite quantity of solvent for dissolving acetylene, and the weight of acetylene gas saturating the solvent at atmospheric pressure and temperature of 15°C;
- 2) Liquefiable gas cylinder means the weight of the cylinder together with any fittings permanently attached thereto and includes the weight of valve;
- 3) Permanent gas cylinder means the weight of the cylinder together with any fittings permanently attached thereto and excludes the weight of valve.

NOTE - Total weight is expressed in kilograms.

**2.15 Water Capacity (Cylinder Shell Volume)** - Actual capacity of the cylinder shell, measured by filling the shell with water.

NOTES:

- 1 Water capacity is expressed in litres.
- 2 The cylinder shell is defined as being empty of any porous mass, *see 2.7.*

## **3 FILLING INSPECTION**

### **3.1 General**

Each cylinder shall be submitted to an inspection prior to, during and immediately after filling. Filling of an acetylene cylinder includes determination of its solvent content and replenishment of its solvent, where applicable. The items described in **3.2** to **3.5** shall be covered by a filling inspection.

Cylinders not fulfilling these requirements shall be clearly identified for further treatment according to the written procedures of the filling station.

Before filling, the identity of the cylinder's owner shall be established and his authorization to fill the cylinder obtained as specified in the Gas Cylinder Rules 2004.

The filling conditions of acetylene cylinders are established based on statutory regulations/standards. Filling conditions for acetylene cylinders are shown in the safe operating diagram in Annex A.

## **3.2 Pre-fill Inspection**

### **3.2.1 *Verification of Stamp-Marking and Necessary Documentation***

The Information required in the following list shall be made available to the filler, for example, by providing him with an appropriate list:

Before filling an acetylene cylinder, it shall be established that:

- a) The cylinder is permitted for filling at the filling station;
- b) The cylinder has not exceeded its due date for periodic inspection;
- c) The porous material contained within the cylinder is fit for further service and does not have a current history of problems, for example by reference to the manufacturer of the material;
- d) The stamp marking, label and colour coding shall be in accordance with statutory requirements

Before filling an acetylene cylinder, the following information shall be made available:

- 1) identification of the porous material;
- 2) type of solvent;
- 3) specified solvent content;
- 4) tare;
- 5) total weight and/or its maximum acetylene charge.

### **3.2.2 *Verification of Serviceable Condition***

It shall be established that each cylinder is in a serviceable condition before filling. It shall therefore be established that the cylinder is clean and free from foreign material, so that the cylinder can be assessed for mechanical damage that would otherwise prevent it from being filled safely, that it does not exhibit any abnormalities that could impair the safety, including arc burns, severe corrosion, heat/fire damage, or have any other significant mechanical damage.

Any fusible plug, if fitted, shall be inspected to ensure that it is in a satisfactory condition.

Cylinders that have been found to be unserviceable shall be clearly identified and segregated in accordance with the written procedures of the filling organization, and shall not be filled.

### **3.2.3 *Verification of Integrity of Permanent Attachments***

Before filling a cylinder, it shall be established that the neck ring/threaded boss is fit for its intended use and that the neck ring, if one exists, is not loose. If there is a permanent valve guard, it shall be checked to ensure that it is in good condition and properly attached. Similarly, the integrity of the foot ring, if fitted, shall be checked for its intended use.

**NOTE** - If a permanent valve guard is exchanged, this might affect the tare of the cylinder.

### **3.2.4** *Verification of Valve Integrity and Suitability*

Before filling a cylinder, it shall be established that the installed valve is suitable for acetylene and is in a satisfactory condition. As a minimum, it shall be established that:

- a) The valve outlet is suitable for the intended use;
- b) The valve is easy to operate;
- c) The valve is free from contaminants;
- d) The valve-operating mechanism is operable (hand wheel or key operated); if the valve is suspected to be blocked, isolate and identify the acetylene cylinder and rectify it in accordance with an appropriate procedure as described in Annex B;
- e) The fusible plug, where present, is undamaged;
- f) The outlet thread and body are undamaged; and
- g) The filling connector attaches securely to the valve.

### **3.3** **Solvent Content**

#### **3.3.1** *Determination of Solvent Content*

Before filling an acetylene cylinder with acetylene, its actual solvent content shall be determined by measuring the pressure, temperature and weight of the cylinder in conjunction with the appropriate documentation. Calibrated weighing scales, manometers and other instruments which have a working range and measuring accuracy appropriate for the cylinder size to be filled shall be used.

Acetylene cylinders take time to reach temperature equilibrium. Special care should be taken if the temperature of the cylinder is very low and/or the pressure is very high or if the cylinder has been exposed to a significant environmental temperature change in the preceding 3 h.

Since the determination of the solvent content is not accurate for acetylene cylinders that contain high amounts of residual gas, cylinders should be emptied until a low amount of residual gas has been reached.

Typically, this would amount to a pressure of less than 7 bar for cylinders with a working pressure of 17 bar or higher and to less than 4 bar for cylinders with a working pressure below 17 bar.

Emptying of the cylinder should be carried out slowly; a typical rate would be 1/8 of the maximum acetylene content per hour. The determination of the solvent content should not be done immediately afterwards as the cylinder will cool down considerably during emptying and will need time to reach temperature equilibrium again.

Calculation of the actual solvent content in cylinders shall be in accordance with Annex C.

**NOTE** -The result of these calculations normally is made available to the filler, for example in the form of a table or a chart indicating the residual acetylene content.

If the weight of the acetylene cylinder after deduction of the residual gas is below the appropriate tare stamped on the cylinder, the solvent loss shall be replenished. The type of solvent shall not be changed for a given acetylene cylinder.

The uncertainty of the method for determining the solvent loss is influenced by several factors including the accuracy of the balance and the accuracy of temperature measurement, etc. These factors should be taken into account for solvent replenishment.

If the weight of the acetylene cylinder after deduction of the residual gas exceeds the appropriate tare stamped on the cylinder, the cylinder shall be examined and the reason for the excess weight shall be determined before further handling.

### **3.3.2** *Solvent Replenishment*

For solvent replenishment, it shall be checked that:

- a) The valve is not blocked/obstructed and that the operation is progressing satisfactorily;
- b) The valve does not leak when it is in the open position; if leakage is suspected, a leak check shall be performed, including around the valve gland nut. The filling process of the cylinder shall be stopped and only recommenced after the leak has been rectified.

During replenishment of the solvent, it shall be ensured that the porous material is not damaged by the pressure with which the solvent is pumped into the cylinder. If no reliable information is available, it is recommended to limit the pressure to a pressure a few bar above the pressure to which cylinders are supposed to be emptied, in accordance with **3.3.1**.

## **3.4** **Inspection During Filling**

### **3.4.1** *General*

During the filling cycle of an acetylene cylinder, which includes the solvent-replenishment stage, the filler shall verify that:

- a) The valve is not blocked/obstructed by checking that the cylinder is filled normally (for example by checking its surface temperature);
- b) The valve and fusible plugs, where fitted, do not leak (external leak tightness). If leakage is suspected, a leak check, including around the valve gland nut, shall be performed. The filling process of the cylinder shall be stopped and only recommenced after the leak has been rectified in a safe manner.

### **3.4.2** *Simultaneous Filling of Acetylene Cylinders*

Acetylene cylinders which are to be filled simultaneously shall have the same type of solvent if the backflow of solvent cannot be prevented by an appropriate technical device.

Special care shall be taken with cylinders having different types of porous material or high amounts of residual gas because they might have different filling properties.

### **3.5 Post-fill Inspection**

#### **3.5.1 Verification of Tightness**

After filling a cylinder, the filler shall ensure that there are no leaks. Leak tests shall be carried out by using an appropriate leak-detection fluid. Checks shall be made

- a) For seat leakage at the valve outlet (internal tightness),
- b) At the interface between the valve and the cylinder, and
- c) At the fusible plugs (if fitted) including the interface between the fusible plug and the cylinder or valve.

#### **3.5.2 Weight and Pressure Checks**

After the cylinder has been filled it shall be verified by weighing that the maximum acetylene content or maximum acetylene charge, respectively, is not exceeded. For example, this can be achieved, by checking that the actual measured weight does not exceed the total weight. Calibrated weighing scales, which have a working range and measurement accuracy appropriate to the respective cylinder size shall be used.

**NOTE** There is no need to check that the pressure corresponds to the stamped working pressure for every cylinder under the following conditions:

- i) the total weight of the cylinder is not exceeded;
- ii) the solvent content has been verified as being correct in accordance with **3.3**.
- iii) The reason is that the acetylene-to-solvent ratio has been established during the type approval of the single cylinder. However, there might be reasons to carry out a pressure check (for example because the cylinder is difficult to fill). If the pressure is too high at ambient temperature and the total weight is not exceeded, it is indicative of the following possible conditions:
  - iv) deficiency of solvent;
  - v) the solvent has become contaminated, for example by water;
  - vi) high concentration of other gases in the acetylene which are not soluble in the solvent used.Conversely, too low a pressure at ambient temperature is indicative of an excessive solvent content.

#### **3.5.3 Valve Protection**

It has to be checked that the valve is protected appropriately, where applicable.

**NOTE** - Appropriate protection can be achieved by a valve-protection cap or a valve guard. Alternatively, a valve can be designed to resist impacts.

**ANNEX A**  
(Clause 3.1)

**SAFE OPERATING DIAGRAM**

**A-1 GENERAL**

In the “Safe operating diagram”, the specified solvent content and the maximum acetylene content (specified by the manufacturer) are shown. A typical diagram is shown in Fig1.

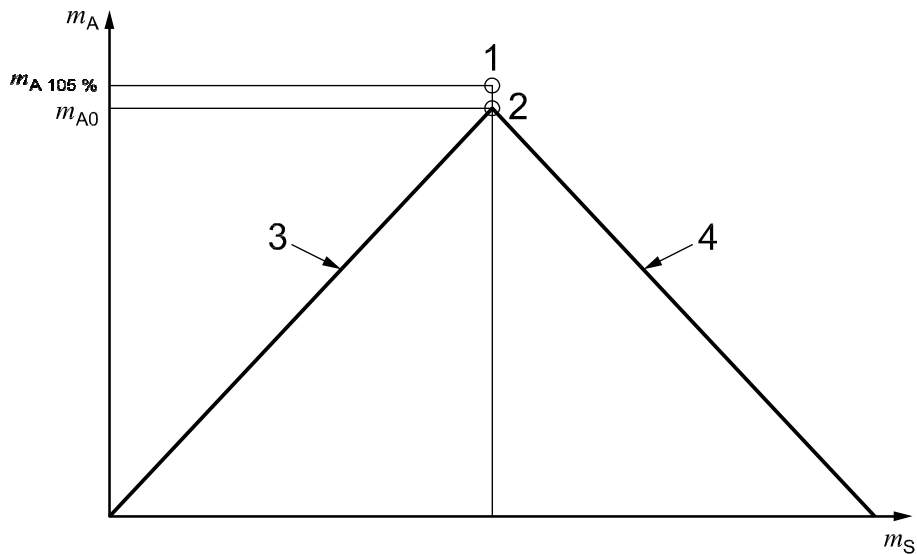

**Key**

- 1 filling conditions for type testing of an individual cylinder
- 2 filling conditions of an individual cylinder
- 3 backfire line
- 4 constant-volume line

- $m_S$  solvent content (x-axis) in kg
- $m_A$  acetylene content (y-axis) in kg
- $m_{A,105\%}$  acetylene content in the cylinder for type testing in kg
- $m_{A0}$  maximum acetylene content of individual cylinder in kg
- $m_{S0}$  specified solvent content of individual cylinder in kg

**Fig. 1 — Example of safe operating diagram**

**A-2 BACKFIRE LINE**

The “backfire line” in Fig.1 is assumed to be straight (constant acetylene-to-solvent ratio) and starts at the origin (no acetylene and no solvent) and extends to the filling conditions of an individual cylinder which has been established to be safe by means of the elevated temperature test and the backfire test and is also approved by the relevant authority.

**NOTE** - For the elevated temperature test and the backfire test, the test cylinders contain 5 percent more acetylene.

The backfire line is given by:

$$m_A = \frac{m_{A0}}{m_{S0}} \cdot m_S \quad (\text{A-1})$$

Filling conditions with the same acetylene-to-solvent ratio as approved for the individual cylinder are represented by the backfire line. Therefore, the filling conditions on and below this line must also be considered as safe.

### **A.3 CONSTANT-VOLUME LINE**

The “constant-volume line” in Fig.1 represents the points where, at a specified temperature, the volume of the acetylene/solvent solution is a constant.

The volume  $V$  (in litres) of an acetylene-to-solvent solution at a given temperature is given by:

$$V = a_4 \cdot m_A + a_5 \cdot m_S \quad (\text{A-2})$$

where  $a_4$  and  $a_5$  are constants with values as given in Table 1

The volume  $V_0$  (in litres), as given by the filling conditions for the individual cylinder, is known to be safe as it passes the elevated temperature test. It is given by:

$$V_0 = a_4 \cdot m_{A0} + a_5 \cdot m_{S0} \quad (\text{A-3})$$

The volume  $V$  of an acetylene/solvent solution in an acetylene cylinder shall not exceed  $V_0$ . Filling conditions with the same volume but a lower acetylene-to-solvent ratio are given by the constant-volume line. This line is obtained by equating Equations (A-2) and (A-3) above and then solving for  $m_A$ :

$$m_A = \frac{a_4 \cdot m_{A0} + a_5 \cdot m_{S0} - a_5 \cdot m_S}{a_4} \quad (\text{A.4})$$

$$= m_{A0} + \frac{a_5}{a_4} \cdot m_{S0} - \frac{a_5}{a_4} \cdot m_S \quad (\text{A-5})$$

$$= m_{A0} + \frac{a_5}{a_4} \cdot (m_{S0} - m_S) \quad (\text{A-6})$$

Filling conditions on the constant-volume line have the same volume but a lower acetylene-to-solvent ratio than the permissible filling conditions for individual cylinders. Therefore, the filling conditions on and below this line must also be considered as safe.

The constants  $a_4$  and  $a_5$  have been determined experimentally for a temperature of 15 °C and the values given in Table 1 shall be used.

**Table 1 — Values for  $a_4$  and  $a_5$**

	<b>Acetone</b>
$a_4$ in l/kg	1.91
$a_5$ in l/kg	1.25
$a_4/a_5$	1.53

#### **A.4 RECOMMENDATIONS FOR FILLING ACETYLENE CYLINDERS**

It follows that the filling conditions for acetylene cylinders with  $m_{A0}$  and  $m_{S0}$  are the optimum operating points and any filling ratio that lies beneath the backfire line and the constant-volume line is safe and may be used. When filling acetylene cylinders, the uncertainty of measuring the pressure, temperature and weight (before and after filling) of the cylinder should be taken into account so that the cylinder is not overfilled. (that is too much acetylene or incorrect acetylene-to-solvent filling ratio).

**ANNEX B**  
(Clause 3.2.4)

**PROCEDURE TO BE ADOPTED WHEN DE-VALVING AND WHEN IT IS  
SUSPECTED THAT A CYLINDER VALVE IS OBSTRUCTED**

**B-1 CHECK FOR OBSTRUCTED VALVE**

The following procedures shall be carried out only by trained personnel. In view of the potential hazards in acetylene cylinders, this operation can lead to injury from stored energy release and fire; hence personnel shall take such precautions as deemed necessary for the work to be performed. When the acetylene, if any, has been released and the pressure within the cylinder reduced to atmospheric pressure, the valve may be removed after an additional check has been made to establish that there is free passage through the valve.

The method adopted shall be a recognized procedure, such as a) followed by either b) or c) below, or one that provides equivalent safeguards.

- a) First check to establish that the actual total weight of the cylinder is the same as the tare stamped on the cylinder, adjusted if necessary to represent the condition of the cylinder being weighed (for example, tare A is likely to require adjustment in most cases). If there is a positive difference, the cylinder may contain either a liquefied gas under pressure or contaminants.
- b) Introduce inert gas at a pressure of up to 5 bar and check its discharge.
- c) Use the device shown in Fig.2. Press the rubber bulb by hand and press the device tight against the valve outlet. If the rubber bulb inflates (tight on the outlet) the free passage through the valve is established. If there is a positive weight difference (actual total weight minus tare), the cylinder may contain contaminants (for example, water or other liquids).

**B-2 VALVE UNOBSTRUCTED**

When it is established that there is no obstruction to gas flow in the cylinder valve and there is no longer residual pressure in the cylinder, the valve may be removed.

**B-3 VALVE OBSTRUCTED**

When a cylinder is found to have an obstructed gas passage in the valve, the cylinder shall be set aside and handled only by personnel specially trained in this task. The preferred method is to partially unscrew the valve within a glanded cap, secured and joined to the cylinder and vented to a safe discharge.

The principles of a suitable device are illustrated in Fig. 3. This procedure shall be performed in a controlled manner in such a way as to avoid personal injury.

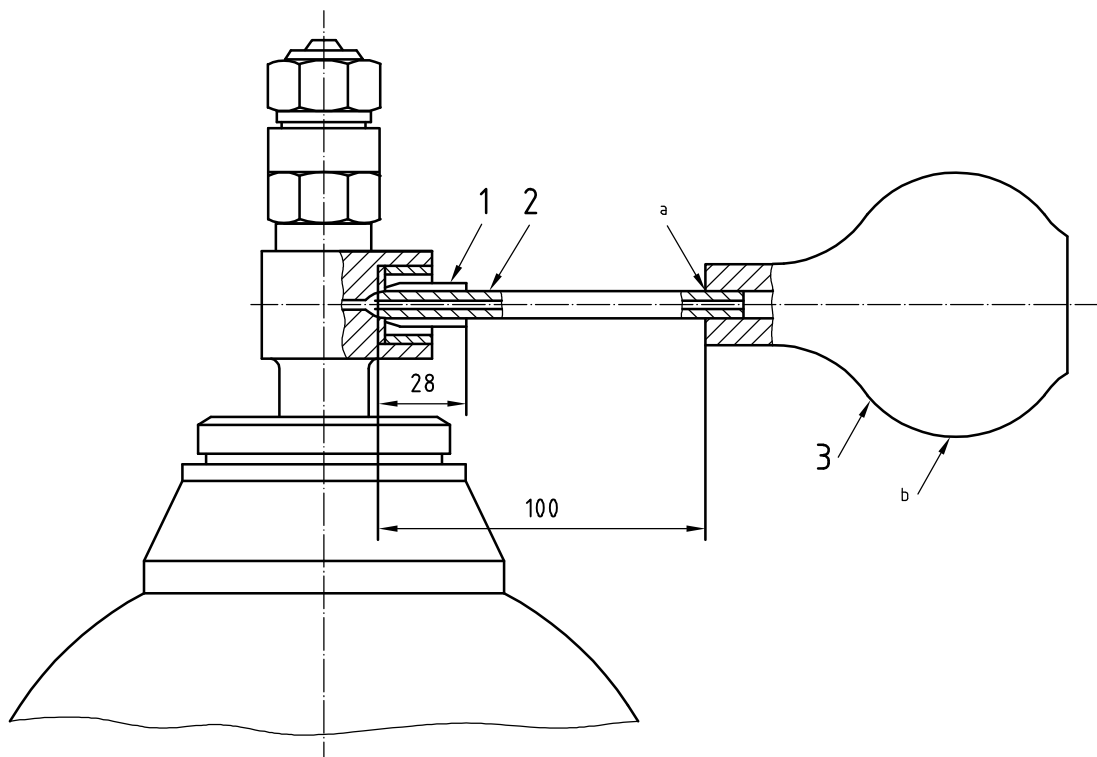

**Key**

- 1 rubber tube (8 mm internal diameter  $\times$  13 mm outer diameter) ground to olive shape and bonded
  - 2 steel tube (3 mm internal diameter  $\times$  8 mm outer diameter)
  - 3 rubber bulb
- a Bonded.
- b Hand pressure.

**Fig 2 — Typical device for detecting an obstructed cylinder valve**

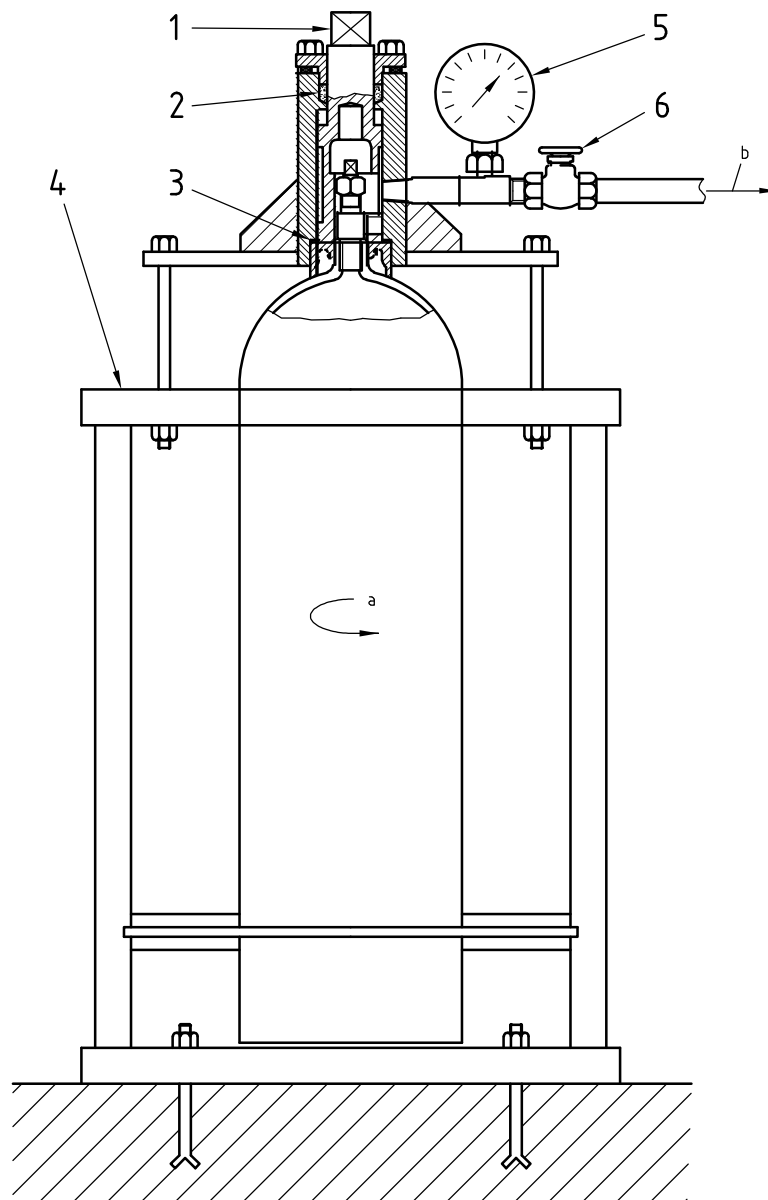

**Key**

- 1 drive for de-valving machine
- 2 gas-tight gland
- 3 gas-tight seal
- 4 cylinder frame and clamping device
- 5 pressure gauge
- 6 vent valve
- a Direction of rotation.
- b To gas disposal.

**Fig. 3— Typical device used for the removal of an obstructed gas cylinder valve**

**ANNEX C**  
(Clause 5.3.1)

**DETERMINATION OF THE SOLVENT CONTENT IN ACETYLENE CYLINDERS**

**C-1** The determination of the actual solvent content in acetylene cylinders returned for filling, containing acetone as the solvent, is achieved by measuring the pressure, temperature and weight of the cylinder and carrying out a subsequent calculation as described below. The result of the calculation normally is made available to the filler, for example in the form of a table or a chart indicating the residual acetylene content.

**C-2** Measurement of the acetylene-cylinder weight alone will only give the sum of the weights of the solvent and acetylene in the cylinder but will not indicate the shortfall or excess of its solvent and acetylene content.

**C-3** The actual acetylene-to-solvent ratio in the cylinder shall be determined using the following equation:

$$F = \frac{m_A}{m_S} = \frac{10^{f(p,T)}}{1 - 10^{f(p,T)}} \quad (\text{C-1})$$

where

$F$  is the actual acetylene-to-solvent ratio;

$m_A$  is the residual acetylene content, in kilograms;

$m_S$  is the actual solvent content, in kilograms;

$f(p,T)$  is a factor dependent upon pressure, temperature and solvent

For acetone,  $f(p,T)$  is determined by the following equation:

$$f(p,T) = \frac{\log_{10}(p + 1,013) - 4,194\ 5 + \frac{712,88}{T + 273,15}}{0,456\ 9 + \frac{207,8}{T + 273,15}} \quad (\text{C-2})$$

where

$p$  = is the actual pressure in the cylinder, in bar;

$T$  = is the temperature of the cylinder, in degrees Celsius.

Based on the calculated actual acetylene-to-solvent ratio  $F$  in the cylinder [see Equation (C-1)], the solvent content actually contained in the acetylene cylinder is calculated as follows:

- Equation to be used for cylinders on which tare  $S$  is stamped:

$$m_S = \frac{m_c - \text{tare}_S + m_{S0} + m_{A,s}}{1 + F} \quad (\text{C-3})$$

where

$m_c$  is the actual weight of the cylinder, in kilograms;  
 $\text{tare}_S$  is the tare as stamped on the cylinder, in kilograms;  
 $m_{S0}$  is the specified solvent content in the cylinder (according to the approval), in kilograms;  
 $m_{A,s}$  is the saturation acetylene, in kilograms.

**NOTE** Equations (C-3) is derived as follows.

The actual weight of the bundle, as measured before filling, can be expressed as follows

$$m_c = \text{tare}_S - m_{A,s} + m_{S0} + m_S + m_A$$

Considering the actual acetylene-to-solvent ratio  $F$  in the bundle, as calculated according to Equation (C-1) and solving for  $m_S$  leads to Equations (C-3) which is used for calculating the actual solvent content contained in the cylinder.